

### STEP LIGHTING SERIES

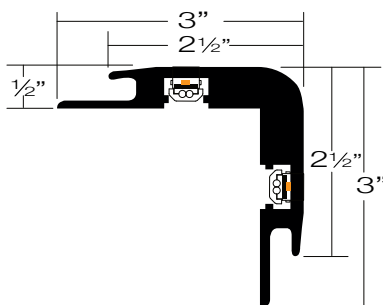

**SL-C/C**  
CARPET TO CARPET

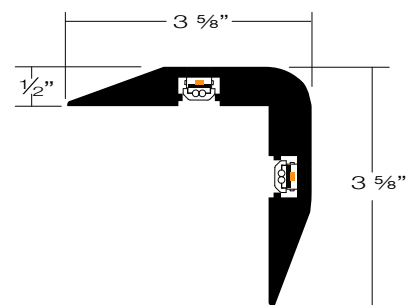

**SL-F/F**  
FLOOR TO FLOOR

**CAREFULLY REVIEW THE FOLLOWING INFORMATION AND INSTALLATION STEPS TO ENSURE THE PRODUCT IS INSTALLED SAFELY AND CORRECTLY.**

**INSTALLATION MUST BE PERFORMED BY A LICENSED CONTRACTOR OR QUALIFIED ELECTRICIAN FAMILIAR WITH APPLICABLE CODES AND SAFETY STANDARDS. IMPROPER INSTALLATION CAN RESULT IN SERIOUS INJURY OR DEATH.**

**FAILURE TO FOLLOW THESE INSTRUCTIONS AND AS A RESULT OF INCORRECT INSTALLATION WILL VOID PRODUCT WARRANTY**

**MANUFACTURER ASSUMES NO LIABILITY FOR PRODUCT OR PROPERTY DAMAGE OR INJURY RESULTING FROM FAILURE TO FOLLOW THESE INSTRUCTIONS, MISUSE OF THE PRODUCT, OR INSTALLATION NOT PERFORMED IN ACCORDANCE WITH LOCAL BUILDING AND ELECTRICAL CODES**

### NEC AND LOCAL CODE AWARENESS

Installation must be done in accordance with (NEC) National Electrical Code and any other local code requirements.

### SAFETY WARNINGS

- Do not install this product outdoors
- Do not install this product in wet locations
- Do not connect direct to 120V, must use 12V transformers

### IMPORTANT INSTALLATION NOTES

- Nice clean and precise cuts are required for a proper installation.
- Proper wiring connections.
- Proper adhesive and even distribution on floor, step extrusion, wireway and endcaps.

### GENERAL NOTES

Contact manufacture with any questions Ph: 661-495-5700 or [info@primuslighting.com](mailto:info@primuslighting.com)

### INDEX

### PAGE

Step lighting series -----	1
Important notes -----	2
Product details & components -----	3
Typical steps layout -----	4
Step Lighting Installation Guide - with wireway and endcaps -----	5
Step Lighting Installation Guide - with wireway only -----	6
Step Lighting Installation Guide - step endcaps only -----	7
Step Lighting Installation Guide - step light only -----	8
Typical Power Feed & Transformers Layout-----	9
Transformers - Maximum runs - Voltage drop -----	10

# STEP LIGHTING (SL) SERIES

INSTALLATION GUIDE  
PRODUCT DETAILS & COMPONENTS



Please review the information below to get familiar with the product, details and all it's components before moving forward with the installation.

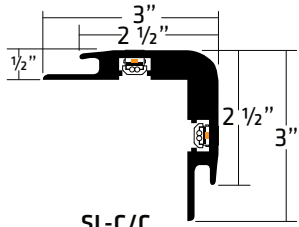

**SL-C/C**  
CARPET TO CARPET

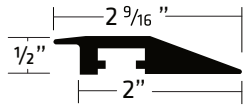

**WW-C/F**  
WIREWAY CARPET TO FLOOR  
(Carpet to carpet available)

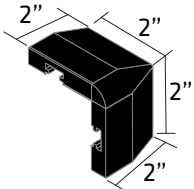

**EC-SL-C/C - R or L**  
CARPET TO CARPET ENDCAP  
RIGHT OR LEFT

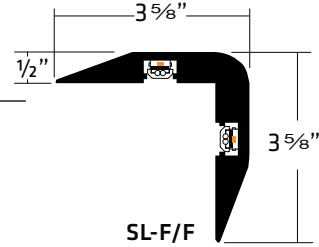
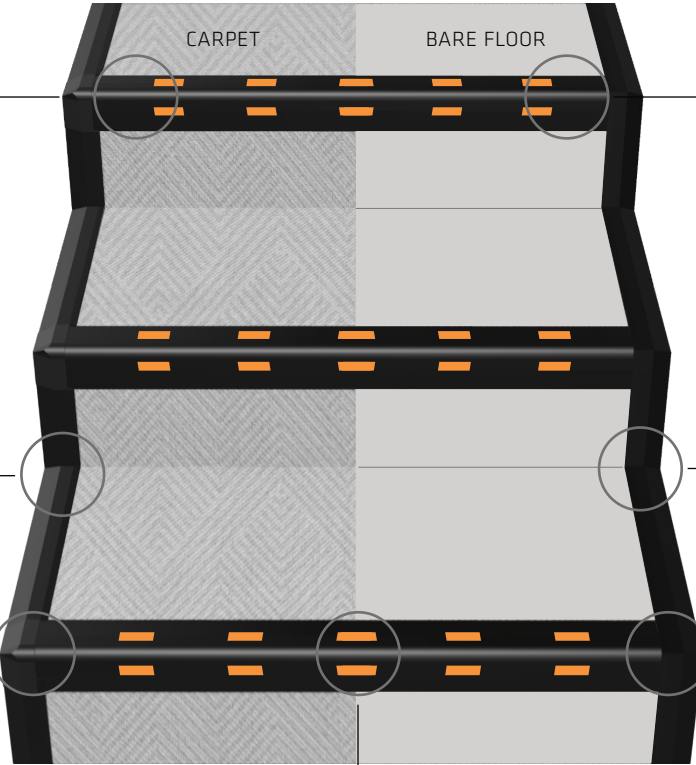

**SL-F/F**  
FLOOR TO FLOOR

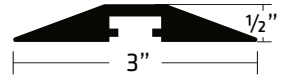

**WW-F/F**  
WIREWAY  
FLOOR TO FLOOR

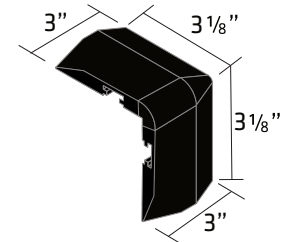

**EC-SL-F/F - R or L**  
FLOOR TO FLOOR ENDCAP  
RIGHT OR LEFT

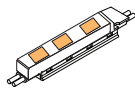

**LED Light**  
(Replaceable)

CARPET/CARPET  
STEP WITH WIREWAY & ENDCAPS

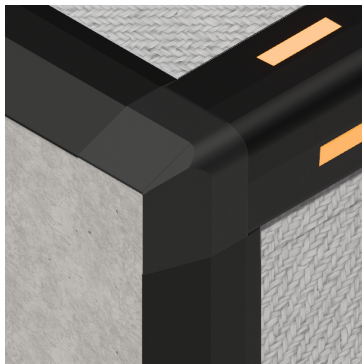

FLOOR/FLOOR  
STEP WITH WIREWAY & ENDCAPS

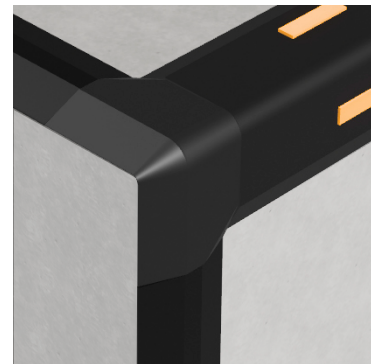

# STEP LIGHTING (SL) SERIES

## INSTALLATION GUIDE TYPICAL STEPS LAYOUT



### TYPICAL STEPS LAYOUT

Review the information below to identify the type of steps layout you have, before moving forward with the installation process.

#### STEPS BETWEEN WALL & SEATS

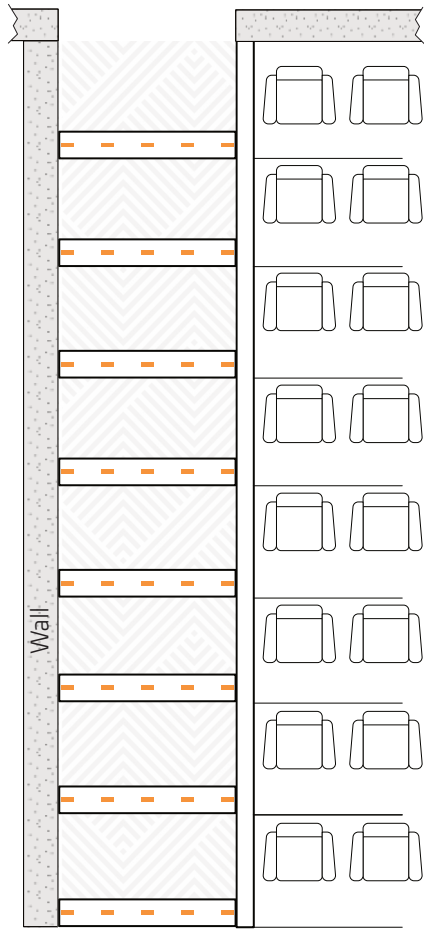

Wall  
Wireway for wiring connections and power feed (Optional)

#### STEPS BETWEEN SEATS

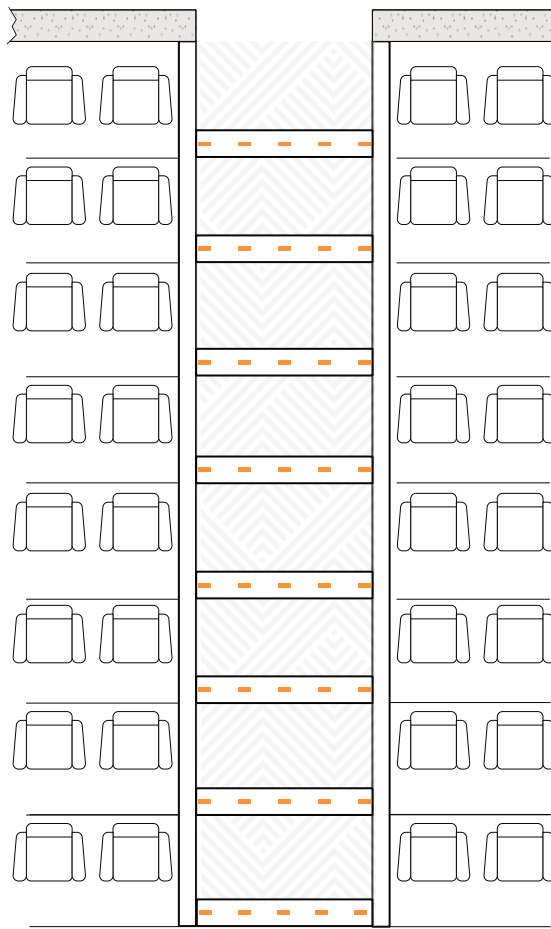

Wireway for wiring connections and power feed (Optional)  
Wireway for uniformity (Optional)

#### STEPS BETWEEN WALLS

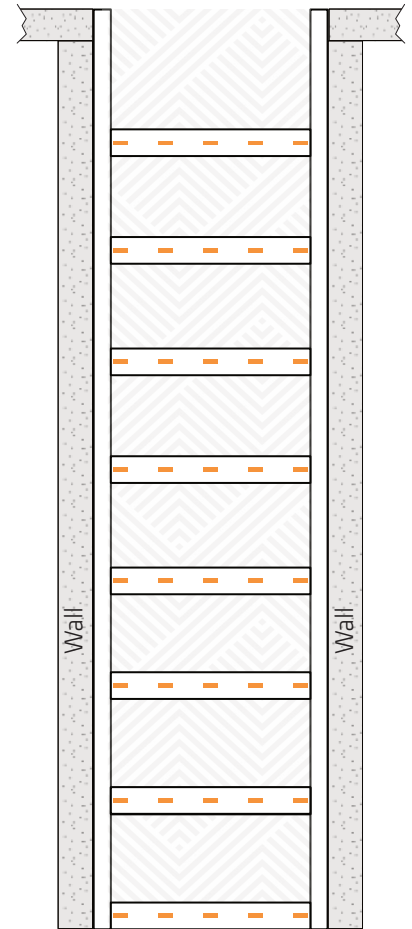

Wireway for wiring connections and power feed (Optional)  
Wireway for uniformity (Optional)

# STEP LIGHTING (SL) SERIES

## INSTALLATION GUIDE STEP LIGHTING WITH WIREWAY AND ENDCAP

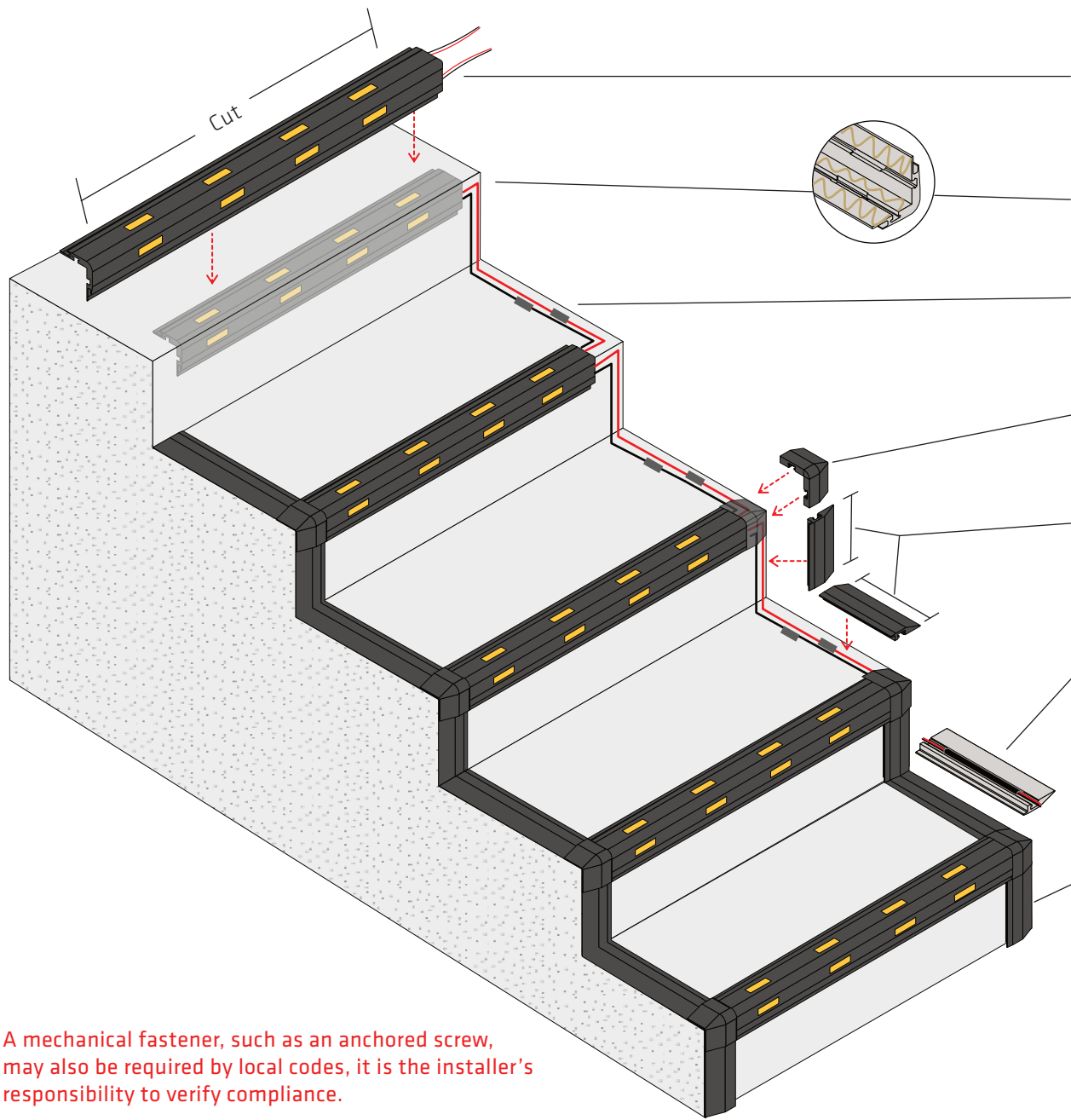

- ① Measure and cut the step extrusion to the proper length, taking into account the space required for the wireway and endcap at the end of each step
- ② After cutting step extrusion to the required length apply the adhesive and attach to the step.
- ③ Make wiring connections between steps and to the 12VAC low voltage transformer and test to make sure all steps are working properly. (Hardware by others)
- ④ Apply adhesive to the endcap and attach to the step.
- ⑤ Measure and cut wireway to the required length, for both tread and riser taking into account the space required for the endcap. Make the appropriate miter cut to the wireway for inside corners.
- ⑥ Hold wireway upside down to Insert the wires into the wireway channel and secure the wires with clip cover.
- ⑦ After wires are inserted and secured inside the wireway apply adhesive on the back of the wireway and attach to the step.

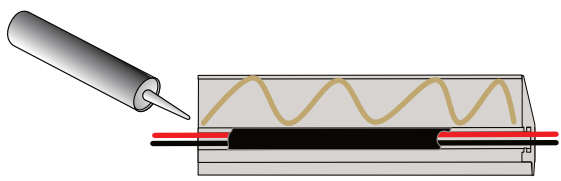

A mechanical fastener, such as an anchored screw, may also be required by local codes, it is the installer's responsibility to verify compliance.

# STEP LIGHTING (SL) SERIES

## INSTALLATION GUIDE STEP LIGHTING WITH WIREWAY ONLY



(For Carpet/Carpet Steps Only)

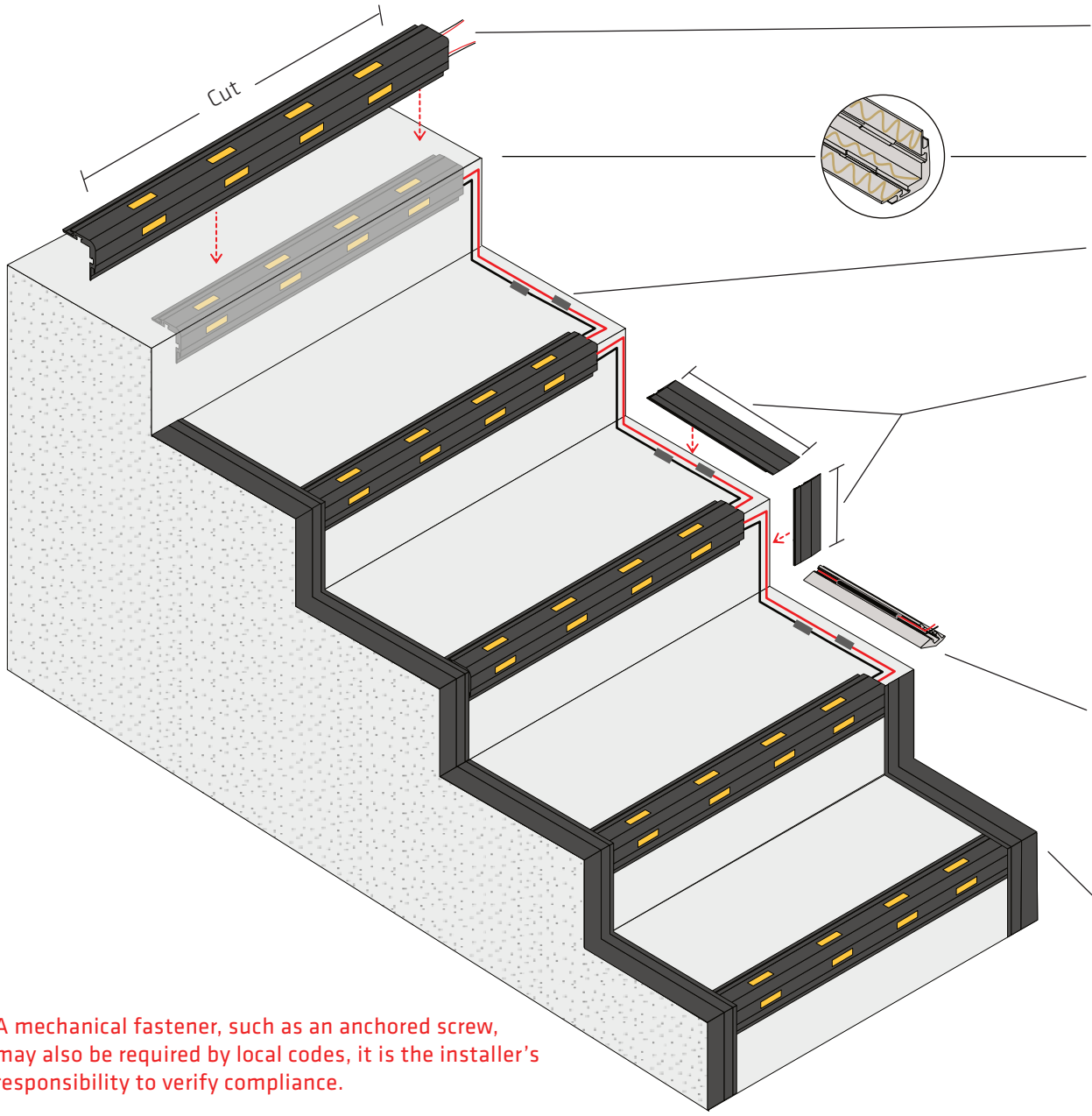

- 1 Measure and cut the step extrusion to the proper length, taking into account the space required for the wireway at the end of each step
- 2 After cutting step extrusion to the required length, apply the adhesive and attach to the step.
- 3 Make wiring connections between steps and to the 12VAC low voltage transformer and test to make sure all steps are working properly. (Hardware by others)
- 4 Measure and cut wireway to the required length, for both tread and riser and make the appropriate miter cuts for inside and outside corners.  
Cut a notch on the wireway for wire access from the step, see images below.

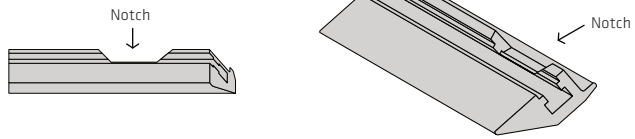

- 5 Hold wireway upside down to Insert the wires into the wireway channel and secure the wires with clip cover.

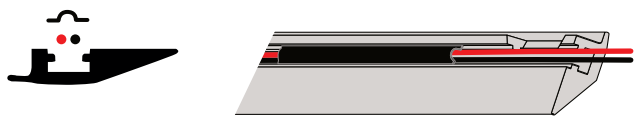

- 6 After wires are inserted and secured inside the wireway apply adhesive on the back of the wireway and attach to the step.

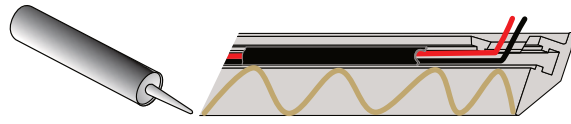

A mechanical fastener, such as an anchored screw, may also be required by local codes, it is the installer's responsibility to verify compliance.

# STEP LIGHTING (SL) SERIES

## INSTALLATION GUIDE

### STEP LIGHTING WITH ENDCAPS ONLY

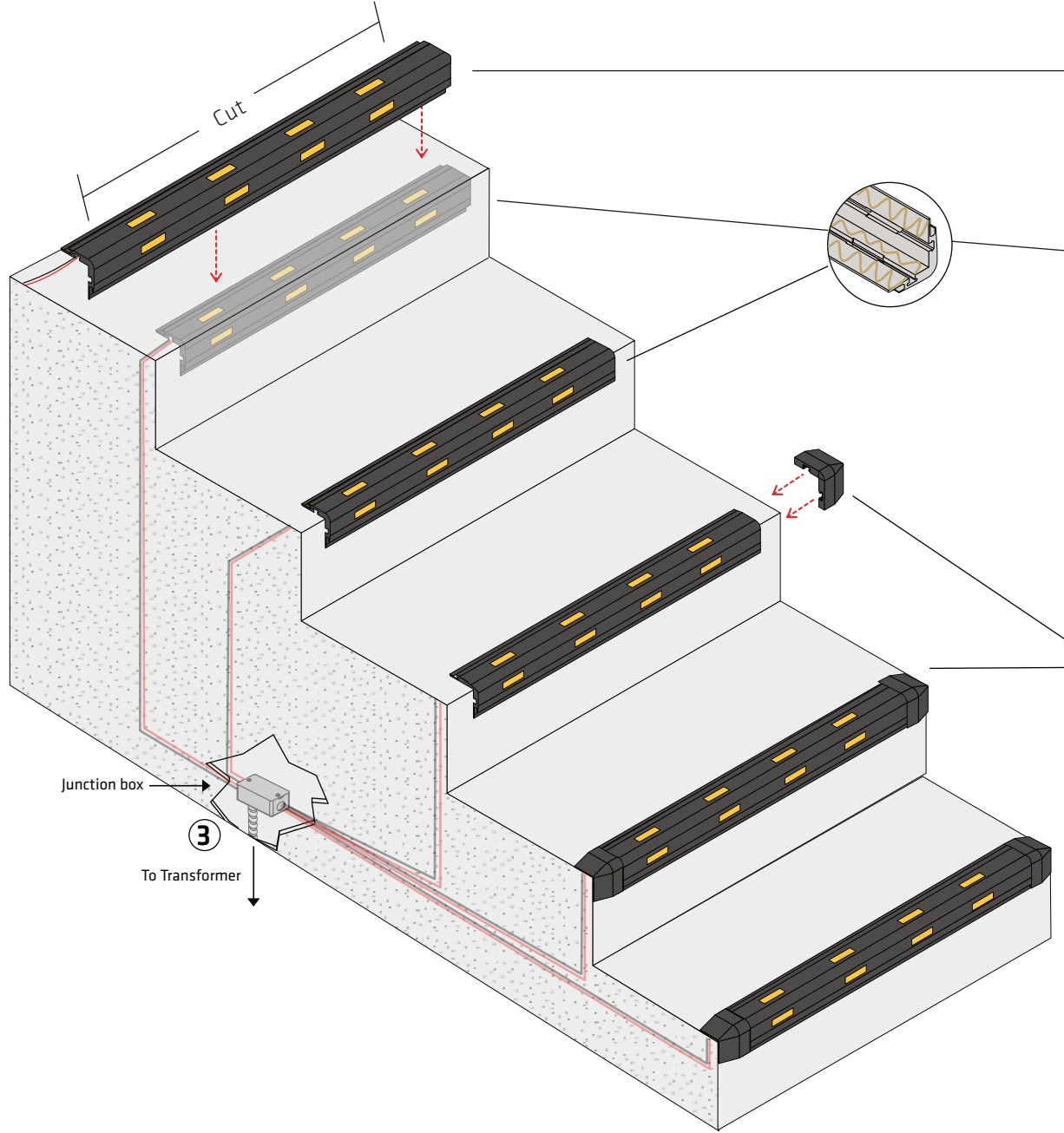

- ① Measure and cut the step extrusion to the proper length, taking into account the space required for the wireway and endcap at the end of each step
- ② After cutting step extrusion to the required length apply the adhesive and attach to the step.
- ③ Make wiring connections for each step to a single or multiple junction boxes and to the 12VAC low voltage transformer and test to make sure all steps are working properly. (Hardware by others)
- ④ Apply adhesive to the endcap and attach to the step.

A mechanical fastener, such as an anchored screw, may also be required by local codes, it is the installer's responsibility to verify compliance.

# STEP LIGHTING (SL) SERIES

## INSTALLATION GUIDE

### STEP LIGHTING ONLY

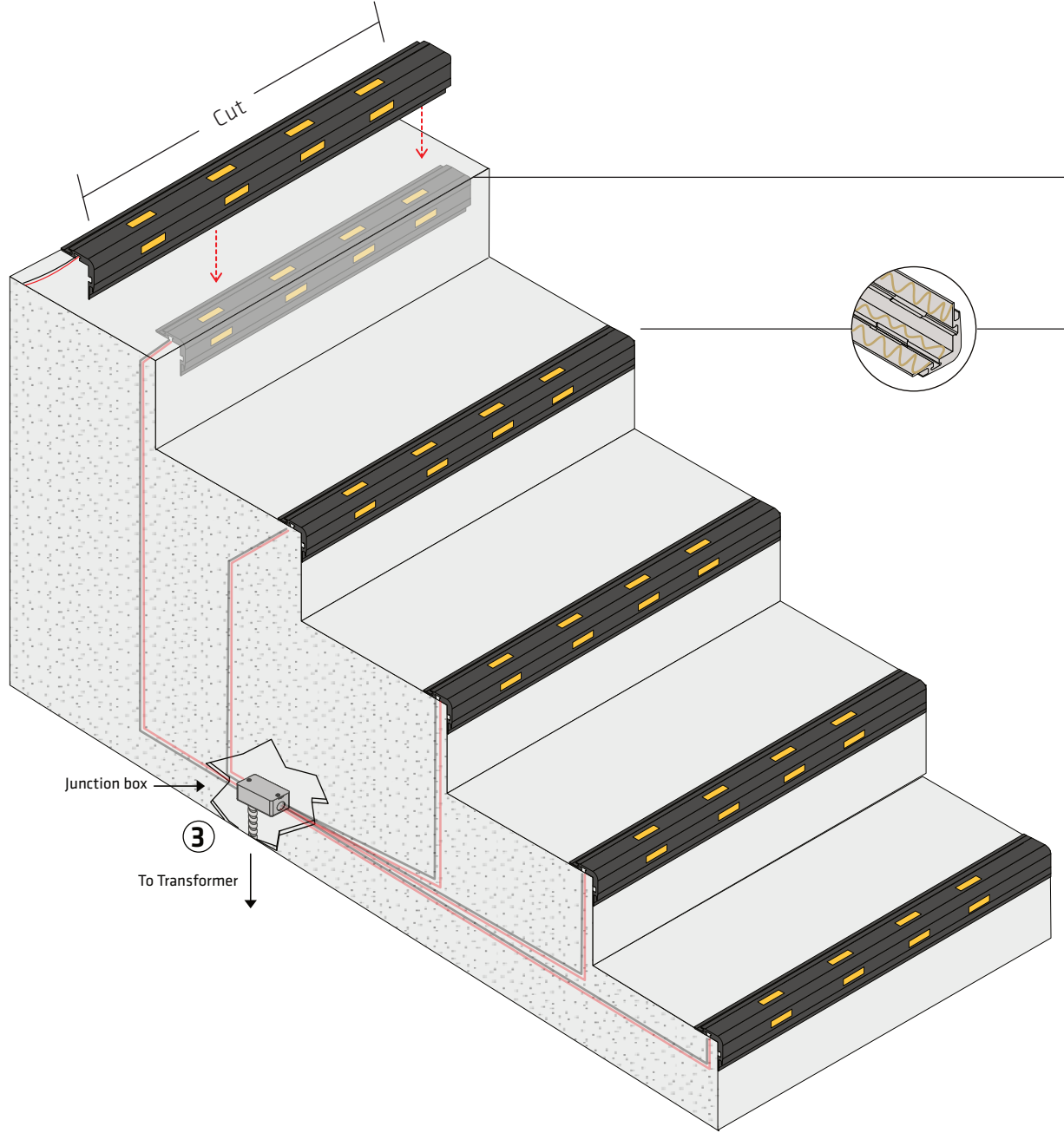

- ① Measure and cut the step extrusion to the proper length.
- ② After cutting step extrusion to the required length apply the adhesive and attach to the step.
- ③ Make wiring connections for each step to a single or multiple junction boxes and to the 12VAC low voltage transformer and test to make sure all steps are working properly. (Hardware by others)

A mechanical fastener, such as an anchored screw, may also be required by local codes, it is the installer's responsibility to verify compliance.

# STEP LIGHTING (SL) SERIES

## INSTALLATION GUIDE

### TYPICAL POWER FEED & TRANSFORMERS LAYOUT



#### TYPICAL STEPS LAYOUT

##### STEPS BETWEEN WALL & SEATS

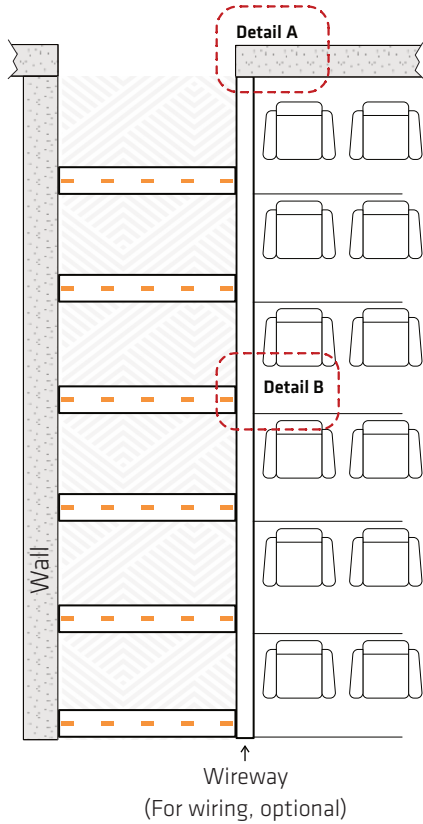

##### STEPS BETWEEN SEATS

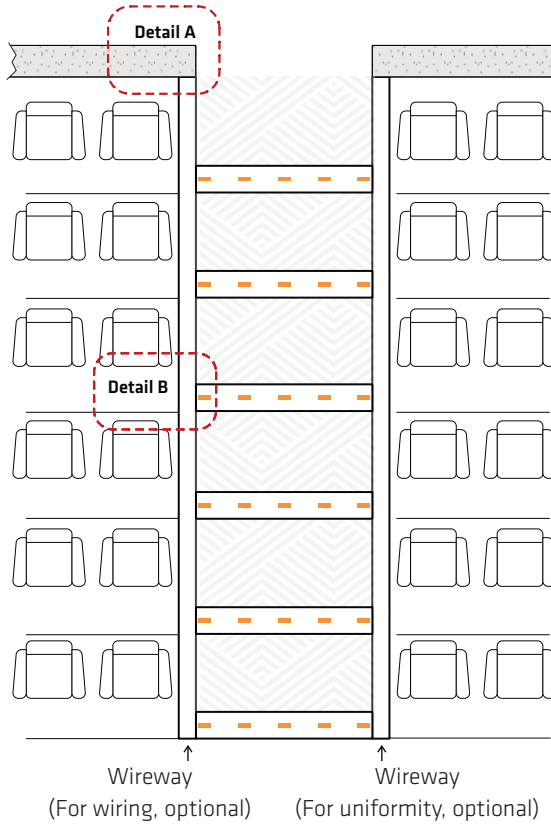

##### STEPS BETWEEN WALLS

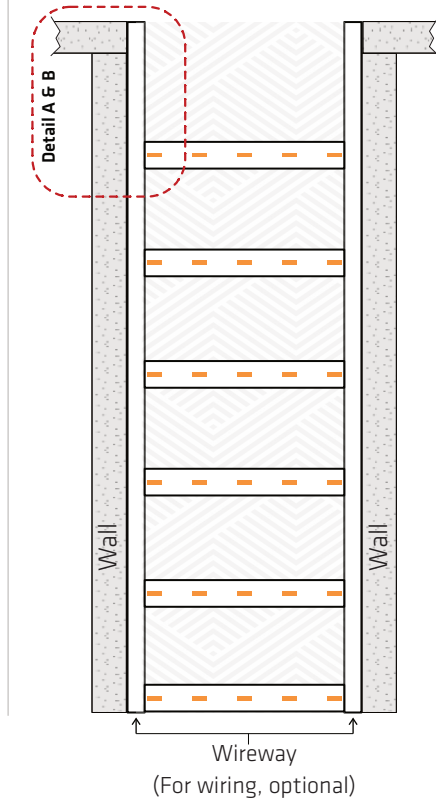

#### TYPICAL POWER FEED

The details below are examples only. The contractor is responsible for determining the most appropriate method to power feed the system. Contractor must identify the optimal location(s) for transformers and J-Boxes to ensure a proper and safe installation and in accordance with code requirements.

##### DETAIL A Wall Junction Box

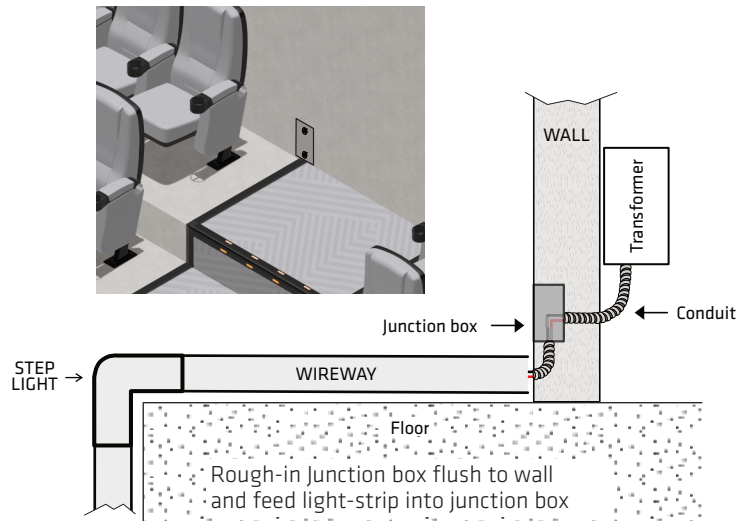

##### DETAIL B Floor Junction Box

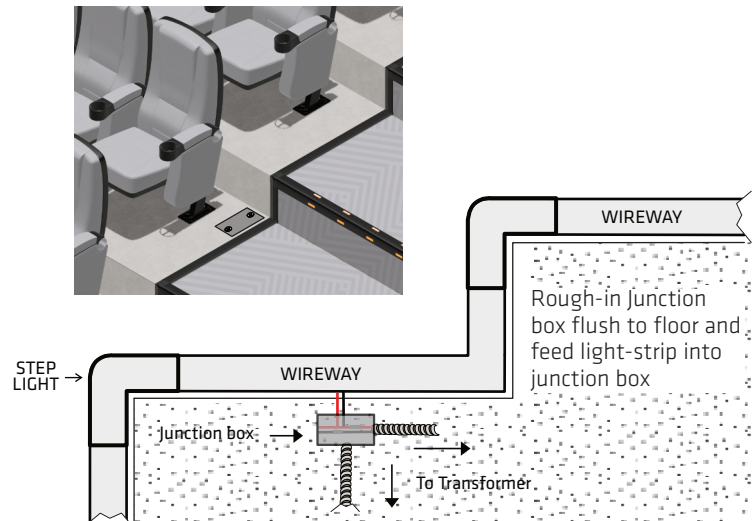

# STEP LIGHTING (SL) SERIES

## INSTALLATION GUIDE

### TRANSFORMERS - MAX RUNS - VOLTAGE DROP



## TRANSFORMERS

- Class 2 magnetic transformer
- Secondary protection provided (reset-able 5A circuit breakers).
- Isolated secondary output.
- Outdoor listed enclosure NEMA 3R.
- Potted for quiet operation and long life.
- Dimmable with MLV dimmers only.
- ETL listed. Meets UL 1571, 1838 and Article 411 of N.E.C.



PART NO.	WATTS	PRIMARY	SECONDARY	BREAKERS	DIMENSIONS	WEIGHT
PLT2 -60 - 120/12	60W	120VAC	12VAC	1 - 5A	6 3/4" X 4 7/8" X 4 5/8	5 LBS
PLT2 -60 - 277/12	60W	277VAC	12VAC	1 - 5A	6 3/4" X 4 7/8" X 4 5/8	5 LBS
PLT2 -100 - 120/12	100W	120VAC	12VAC	2 - 5A	6 3/4" X 4 7/8" X 4 5/8	10 LBS
PLT2 -100 - 277/12	100W	277VAC	12VAC	2 - 5A	6 3/4" X 4 7/8" X 4 5/8	10 LBS
PLT2 -150 - 120/12	150W	120VAC	12VAC	3 - 5A	6 3/4" X 4 7/8" X 4 5/8	11 LBS
PLT2 -150 - 277/12	150W	277VAC	12VAC	3 - 5A	6 3/4" X 4 7/8" X 4 5/8	11 LBS
PLT2 -250 - 120/12	250W	120VAC	12VAC	4 - 5A	6 3/4" X 4 7/8" X 4 5/8	13 LBS
PLT2 -250 - 277/12	250W	277VAC	12VAC	4 - 5A	6 3/4" X 4 7/8" X 4 5/8	13 LBS

## MAXIMUM RUNS

The maximum recommended runs below are based on 80% load of 60W, 12V, 5A (80% of 60W is 48W, 12V, 4A).

LED SPACING	WATTS / LED MODULE	LEDs ON TREAD & RISER		LEDs ON TREAD or RISER	
		WATTS / FT	MAX RUNS	WATTS / FT	MAX RUNS
9" O/C	0.25W	0.66W	72' (48W, 4A)	0.33W	144' (48W, 4A)
12" O/C	0.25W	0.50W	96' (48W, 4A)	0.25W	192' (48W, 4A)
18" O/C	0.25W	0.34W	141' (48W, 4A)	0.17W	282' (48W, 4A)

## VOLTAGE DROP

Maximum wire distance between the transformer and lighting system to prevent voltage drop

LOAD (Watts)	8AWG	10AWG	12AWG	14AWG	16AWG	18AWG	20AWG
10W	1124'	722'	454'	285'	179'	113'	71'
20W	559'	359'	226'	142'	89'	56'	35'
30W	373'	240'	151'	95'	60'	38'	23'
40W	280'	180'	113'	71'	45'	28'	18'
280'	224'	144'	90'	57'	36'	23'	14'
60W	187'	120'	75'	47'	30'	19'	12'