

CV2 Installation Guide

General Notes

- Luminaire to be installed by a qualified electrician and in accordance with NEC and local codes
- Do not install on or nearby combustible materials
- Fixture is ETL listed "Damp Rated"

Fixture Description

The CV2 (formally ALX2LP) is a high performance, small profile, cove luminaire offering either symmetrical or asymmetrical distribution. Runs can be configured in both straight or flex configurations to accommodate any possible shape, pattern or run length. Internal 0-10v dimming drivers are standard.

Construction Details

Housing	Snap together Extruded Aluminum housing
Lens	Extruded snap on DR Acrylic lens with white frosted finish for smooth distribution
LED Boards	Standard LEDs 60,000hours (L70), high uniformity 90CRI, 2700K to 4000K Special LEDs include Static Colors, RGB, RGBW, Tunable White and Dim to Off.
LED Drivers	Standard drivers are 120/277v (347v optional) and feature 0-10v control. They are programmed Low, Medium, High or a specific performance level Special driver control features include Dali, Lutron, 2-wire/Triac and others
Pre-wired	Fixtures are pre-wired with both line and control runners.
Endcaps / Joiners	Endcaps with 1/2" Ko's are standard on both ends. Continuous runs feature an internal joiner and are pre-wired with line and control wires.
Finish	Satin Anodized or Polyester white paint is standard. Powder-coat optional
Fixture Lengths	Continuous runs to fill any cove application. Multiple fixtures connect with internal joiners.

Fixture Organization and Prep

All CV2 fixtures are shipped identified by type and fixture length. Larger projects usually include marked up plans or worksheets to properly identify run locations by room. #.

See Next Page For More Product Details

Read and understand the following product and safety instructions to ensure safe and successful installation

(FLX) Field Curvable Fixtures Instructions

TOP VIEW

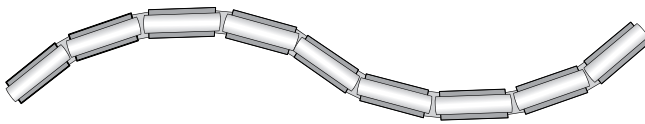

MINIMUM RADIUS AND COVE REQUIREMENTS

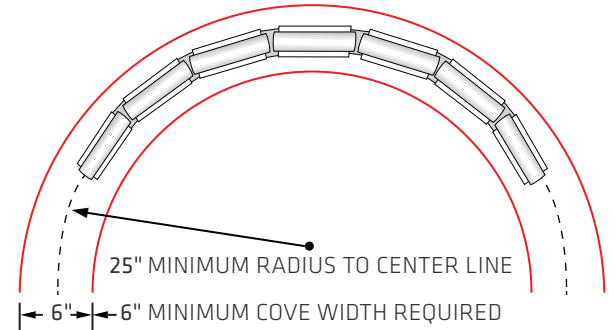

SIDE VIEW

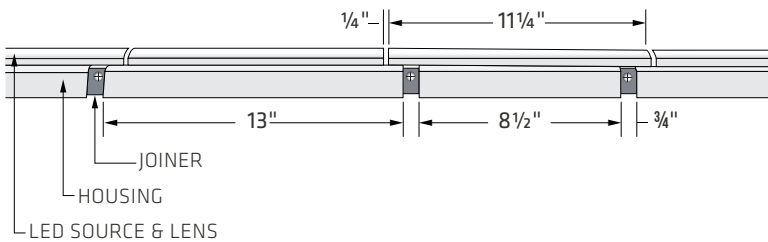

END VIEW

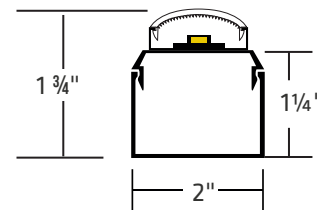

The above dimensions can vary depending on the requirements

Tools Required:

Wire stripper, 5/16" nut driver, flat screw driver and philips screw driver. (Mounting screws and wire nuts by others)



See Next Page For Installation Steps

INSTALLATION MUST BE DONE BY A PROFESSIONAL OR QUALIFIED ELECTRICIAN

COVE 2 - (CV2) SERIES

INSTALLATION STEPS 1-3



STEP 1

Insert flat screw driver at the male end of one section between the flex joiner and the aluminum snap cover to access the wiring and joiner to connect to the next section. *(Do not remove any lens cover.)*

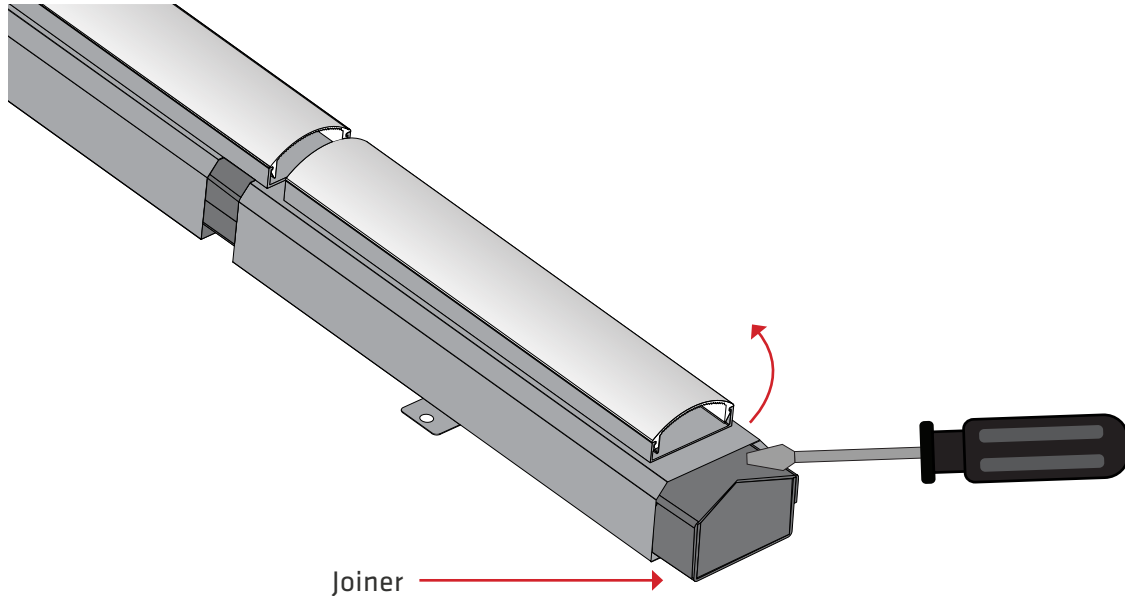

STEP 2

Repeat step 1 to another section on the opposite end without the flex joiner (*Female end*) to start connecting sections. *(Do not remove any lens cover.)*

STEP 3

Insert flex joiner in to the pre-attached screw on the next section, connect and secure using the provided flat washer and nylock nut, must use a 5/16" nut driver.

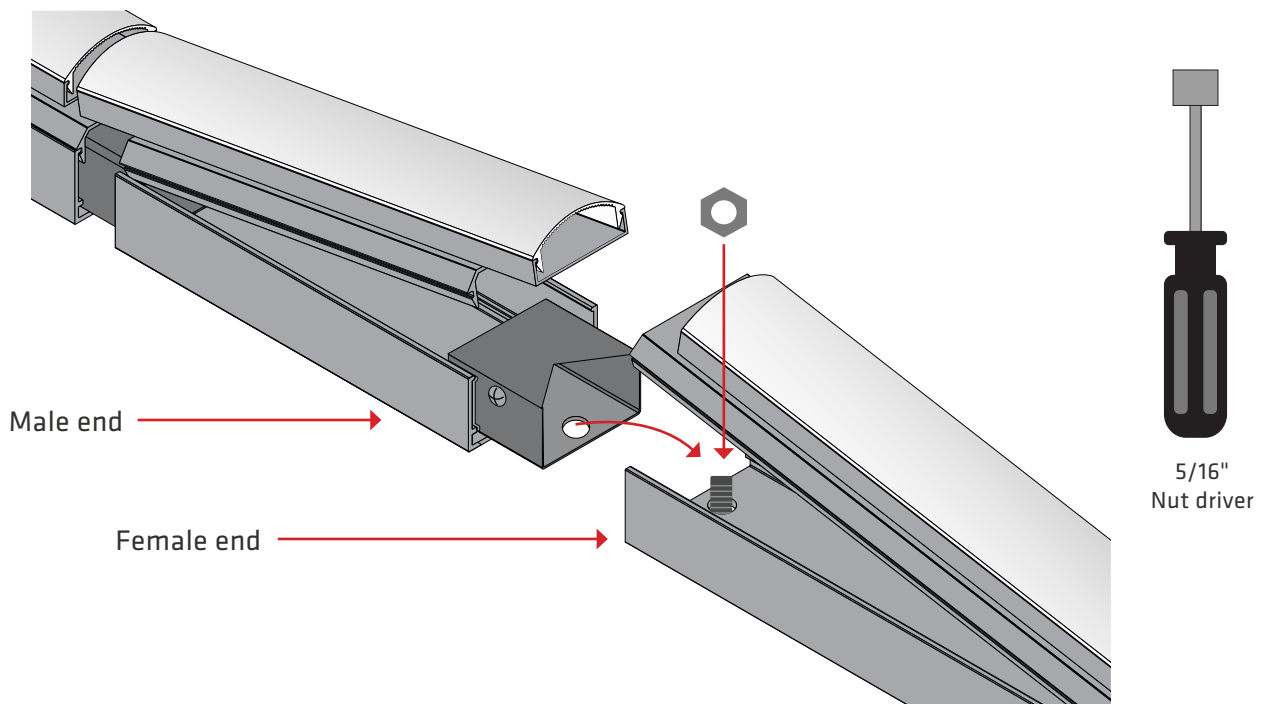

STEP 4

Identify wires and connect power and dimming wires from one section to another section. Repeat same steps to connect more sections to complete the required overall run length.

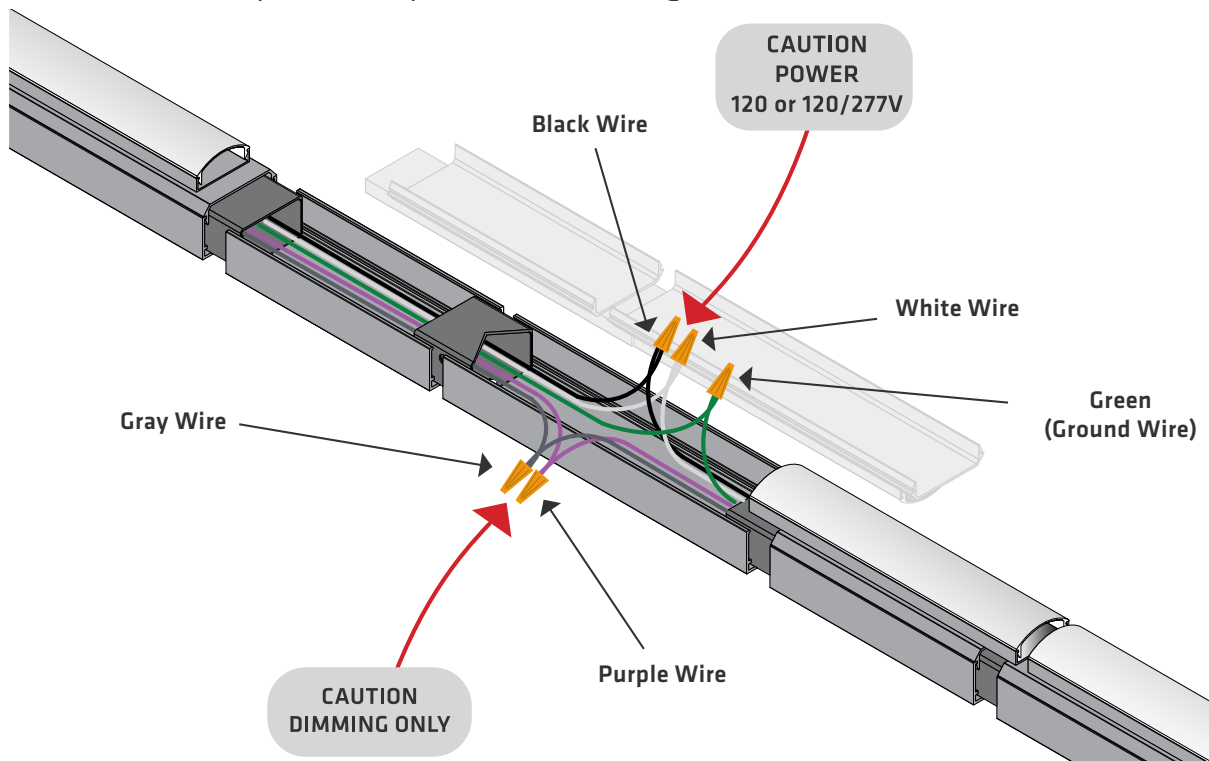

STEP 5

Service power can be connected at the end of the run using the provided endcap with K/O or on the side of any section, field-drilled with unibit and use a snap in conduit fitting. (*Conduit fittings and conduit by others*)

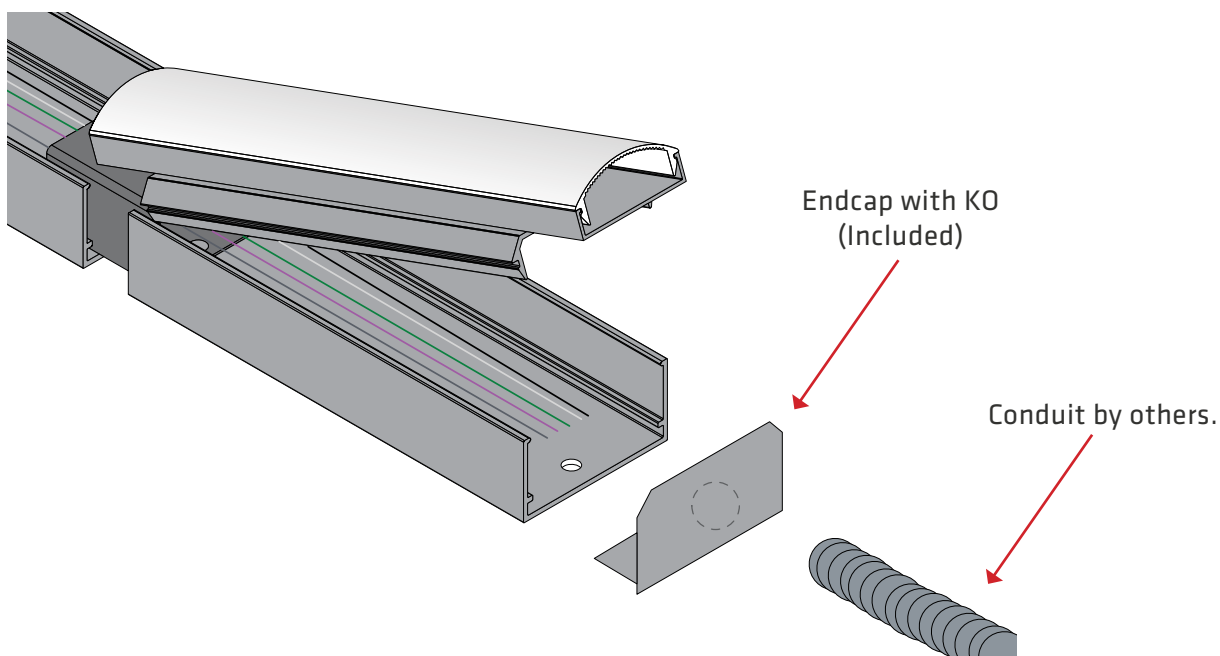

COVE 2 - (CV2) SERIES

INSTALLATION STEPS 6-7



STEP 6

Secure the fixture to the mounting surface using the pre-drilled mounting holes or use the tab mounting holes if fixture was ordered with mounting tabs . (Mounting screws by others)

INSIDE SCREW MOUNT

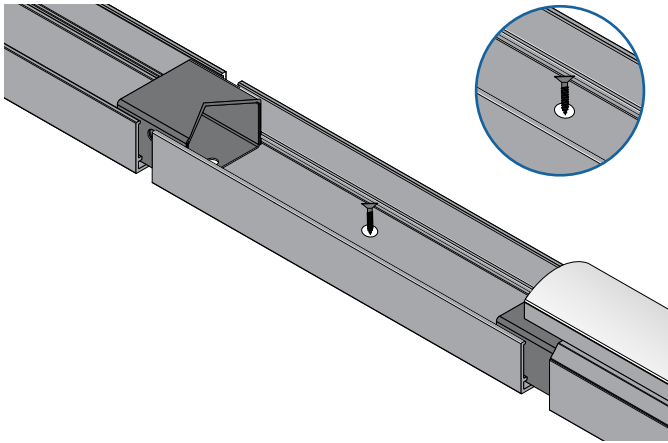

TAB MOUNT

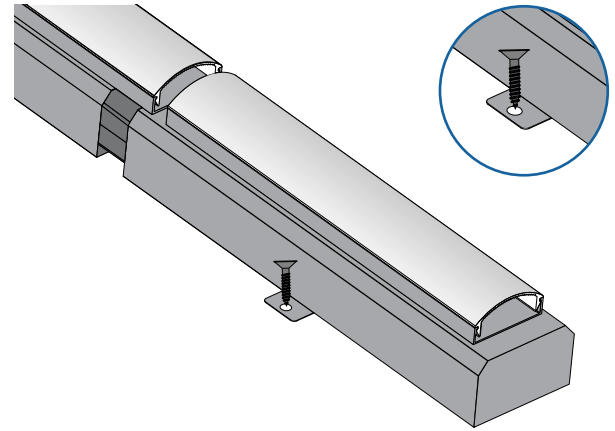

STEP 7

Snap covers back on to close the fixture and complete the installation.

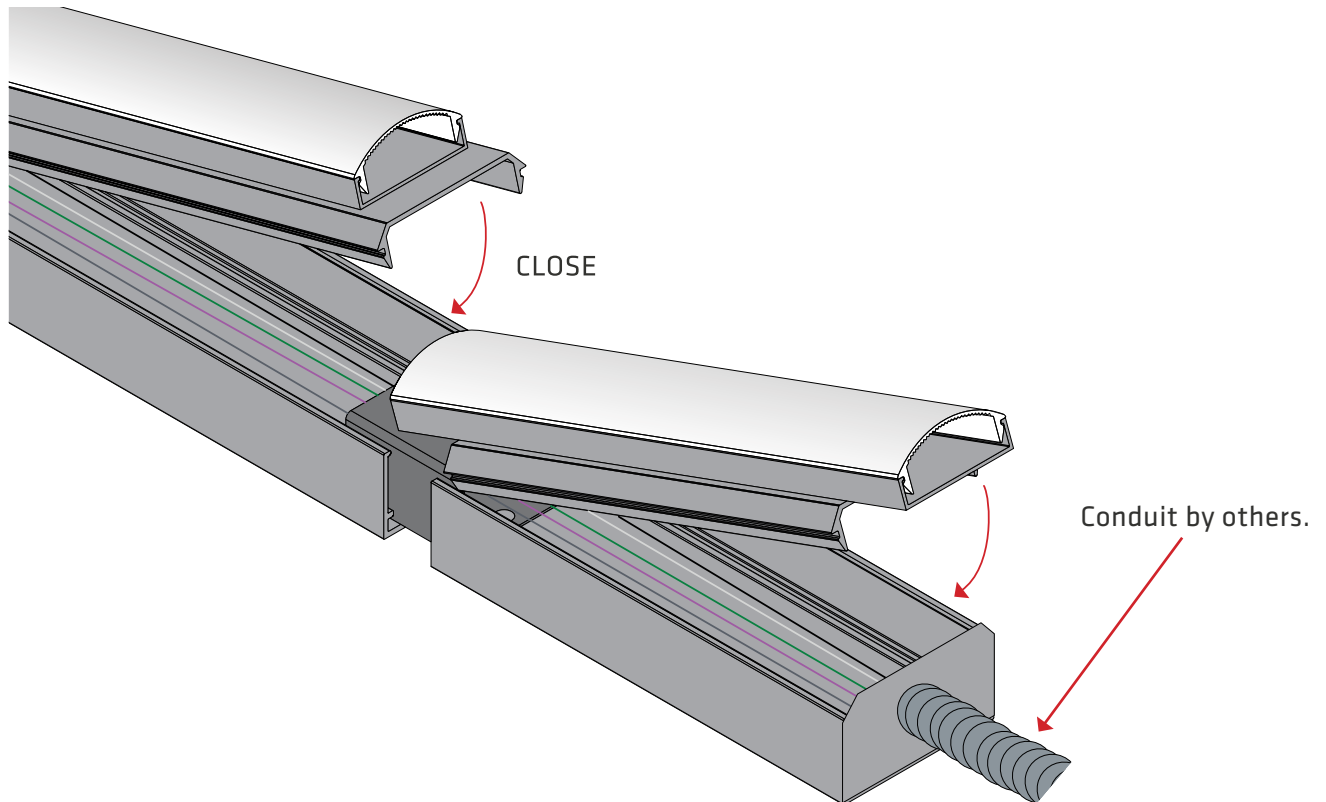

(ST) Straight Fixtures Instructions

Use the same steps above for straight fixtures installation

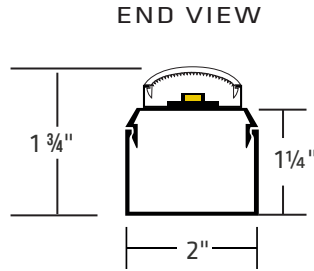

Contact factory with any questions: 626-442-4600 or technical@primuslighting.com