

# COVE 2 - (CV2) SERIES

FIELD CURVABLE COVE / INDIRECT LIGHTING

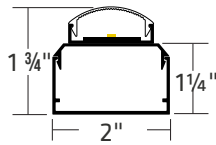

CV2

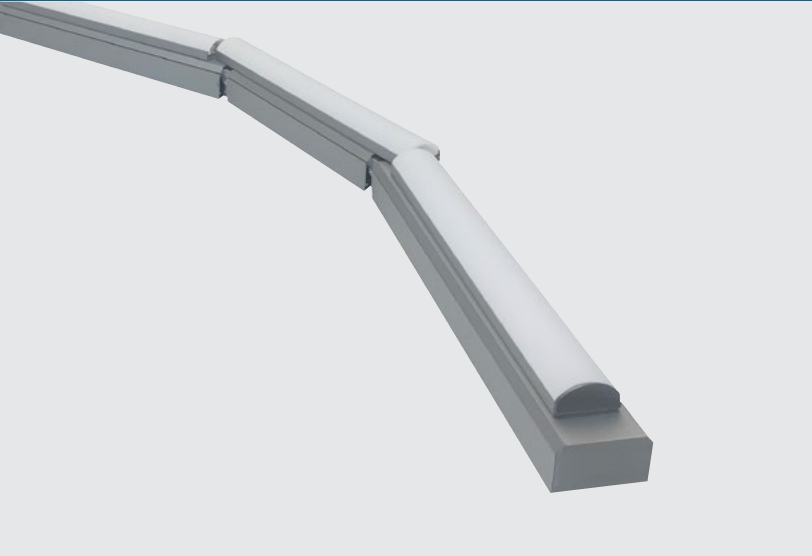
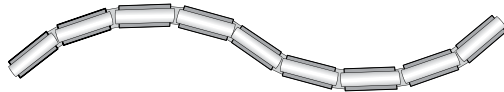

(FLX) FIELD CURVABLE



(ST) STRAIGHT

PROJECT

TYPE

NOTES

## FEATURES

### CONSTRUCTION

High quality precision extruded aluminum that has a superior strength-to-weight ratio than steel allowing for longer runs and a premium finish and wide spread acrylic lens for broad even light distribution.

### FIELD CURVABLE

Field curvable feature allows you to shape the fixture to any architectural contour or curve as tight as a 2' radius.

### STRAIGHT CONFIGURATION

Continuous straight runs up to 12' in length with one single extrusion. Longer runs are made using joiners in the field

### CUSTOMIZATION

Many options of the latest LED types, LED colors, drivers, finishes, configurations, mounting & lengths to customize your fixture.

SERIES	LED TYPE	LUMENS	DRIVER	CONFIGURATION	MOUNTING	FINISH	LENGTH
CV2	<b>STANDARD LED</b>	<b>FOR STANDARD LED</b>	<b>FOR STANDARD LED</b>	<b>FLX</b> FIELD CURVABLE  <b>ST</b> STRAIGHT	<b>IM</b> INSIDE MOUNT (Standard)  <b>TB</b> TAB MOUNT (Optional)	<b>W</b> WHITE <b>S</b> SATIN <b>B</b> BLACK <b>C</b> CUSTOM <b>A</b> ANTI MICROBIAL	SPECIFY
	<b>27K</b> 2700k	<b>L</b> LOW	<b>UNV0%</b> 0-10V0%				
	<b>30K</b> 3000k	<b>M</b> MEDIUM	<b>UNV1%</b> 0-10V1%				
	<b>35K</b> 3500k	<b>H</b> HIGH	<b>UNV10%</b> 0-10V10%				
	<b>40K</b> 4000k	<b>CL</b> CUSTOM LUMENS	<b>UNVCD%</b> 0-10VCD				
			<b>TRIAC</b> 2 WIRE				
			<b>DALI</b> DALI				
			<b>LTRN</b> LUTRON				
	<b>SPECIAL LED</b>	<b>FOR SPECIAL LED</b>	<b>FOR SPECIAL LED</b>				
	<b>R</b> RED <b>G</b> GREEN <b>B</b> BLUE <b>RGBW</b> RGBW <b>DTW</b> DIM TO WARM <b>TW</b> TUNABLE WHITE	Specify required lumens or consult factory	Refer to driver options in compatibility chart or consult factory				
Refer to PG.1	Refer to PG. 3	Refer to PG. 3	Refer to PG. 3	Refer to PG. 4	Refer to PG. 5	Refer to PG. 5	Refer to PG. 6



# COVE 2 - (CV2) SERIES

## SERIES - SPECIFICATIONS



### SERIES

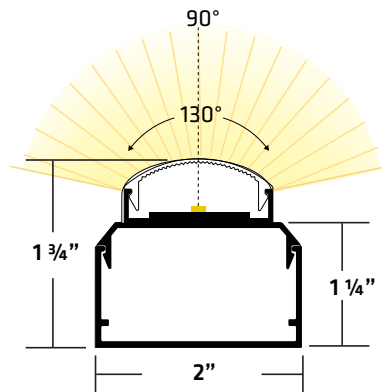

CV2  
COVE 2

### SPECIFICATIONS

#### HOUSING

High quality extruded aluminum snap together housing up to 12' long in one single and continuous housing. Continuous longer runs can be made in the field by connecting multiple fixtures using our internal joiners.

#### LENS

Extruded semi-rounded snap on DR acrylic with white frosted finish for widespread even distribution.

#### LED'S

**Standard** LED'S 60,000 hours. (L70), High uniformity 90CRI, 2700K TO 4000K, refer to page 3 for lumen details and options.

**Special** LED'S red, green, blue, RGBW, Dim to warm, Tunable white, refer to page 3 for details and options.

#### LED DRIVERS

Integral, universal voltage (120/277), 0-10V with custom program dimming options, Triac, Dali, Lutron, refer to page 3 for details and options.

#### OPTIONS

(FLX) Field curvable or (ST) Straight configurations, consult factory for other options or requirements, refer to page 4 for details.

#### ENDCAPS

Aluminum pre-installed endcaps that match housing finish.

#### MOUNTING

Two options, standard (IM) inside screw mount and optional (TM) tab mount, refer to page 5 for details.

#### FINISH

Powder coat and Satin anodized. White, satin and black are standard finishes, refer to page 5 for more details, custom colors and antimicrobial finish options.

#### FIXTURE LENGTHS

Specify the overall fixture lengths required for both field curvable (FLX) and straight (ST) configurations, refer to page 6 for more details.

### COMPLIANCE CERTIFICATIONS



# COVE 2 - (CV2) SERIES

## LED TYPES-DRIVERS-COMPATIBILITY



### LED TYPES

STANDARD LED'S		DESCRIPTION									
COLOR		CRI	(L) LOW LUMENS			(M) MEDIUM LUMENS			(H) HIGH LUMENS		
<b>27k</b>	2700K	CRI 90	584 L/FT	3.5 W/FT	163 L/W	1038 L/FT	6.5 W/FT	158 L/W	1390 L/FT	9.0 W/FT	154 L/W
<b>30k</b>	3000K	CRI 90	604 L/FT	3.5 W/FT	169 L/W	1075 L/FT	6.5 W/FT	163 L/W	1439 L/FT	9.0 W/FT	159 L/W
<b>35k</b>	3500K	CRI 90	625 L/FT	3.5 W/FT	175 L/W	1111 L/FT	6.5 W/FT	169 L/W	1488 L/FT	9.0 W/FT	164 L/W
<b>40k</b>	4000K	CRI 90	645 L/FT	3.5 W/FT	181 L/W	1148 L/FT	6.5 W/FT	174 L/W	1537 L/FT	9.0 W/FT	170 L/W

**(CL)** Custom Lumens. Custom and higher lumen available. Other colors and higher Kelvin also available, consult factory.

SPECIAL LED'S	DESCRIPTION		LUMENS
<b>R</b>	RED	Static Red LED	Specify Required Lumens or Consult factory
<b>G</b>	GREEN	Static Green LED	
<b>B</b>	BLUE	Static Blue LED	
<b>RGBW</b>	RGBW	Color Tuning	
<b>DTW</b>	DIM TO WARM	4000k - 1800K	
<b>TW</b>	TUNABLE WHITE	2700k - 6500k	

Specify or consult factory for any other type of LED requirements not shown above such as led type, LED color, lumens, etc.

### LED DRIVERS (Integral)

DRIVER	DESCRIPTION			
<b>UNV0%</b>	0 - 10V Dimming Driver	0% Dimming ( Dim to Off)	120/277V	( 347V Available )
<b>UNV1%</b>	0 - 10V Dimming Driver	1% Dimming	120/277V	( 347V Available )
<b>UNV10%</b>	0 - 10V Dimming Driver	10% Dimming	120/277V	( 347V Available )
<b>UNV(CD)%</b>	0 - 10V Dimming Driver	Custom Dimming (Specify %)	120/277V	( 347V Available )
<b>TRIAC</b>	2 Wire Dimming Driver	2 Wire Phase Triac Dimming	120/277V	
<b>DALI</b>	Dali Dimming Driver	Dali, Specify Dali Type Required	120/277V	( 347V Available )
<b>LTRN</b>	Lutron Dimming Driver	Lutron, Specify Type Required	120/277V	

Specify or consult factory for any other type of LED DRIVER requirements not shown above.

### LED TYPES & DRIVERS COMPATIBILITY

STANDARD LED'S	DRIVER						
<b>27k</b>	UNV0%	UNV1%	UNV10%	UNV(CD)%	TRIAC	DALI	LUTRON
<b>30k</b>	UNV0%	UNV1%	UNV10%	UNV(CD)%	TRIAC	DALI	LUTRON
<b>35k</b>	UNV0%	UNV1%	UNV10%	UNV(CD)%	TRIAC	DALI	LUTRON
<b>40k</b>	UNV0%	UNV1%	UNV10%	UNV(CD)%	TRIAC	DALI	LUTRON
<b>SPECIAL LED'S</b>							
<b>R</b>	UNV0%	UNV1%	UNV10%	UNV(CD)%	TRIAC	DALI	LUTRON
<b>G</b>	UNV0%	UNV1%	UNV10%	UNV(CD)%	TRIAC	DALI	LUTRON
<b>B</b>	UNV0%	UNV1%	UNV10%	UNV(CD)%	TRIAC	DALI	LUTRON
<b>RGBW</b>						DALI	LUTRON
<b>DTW</b>	UNV0%	UNV1%	UNV10%	UNV(CD)%		DALI	LUTRON
<b>TW</b>	UNV0%	UNV1%	UNV10%	UNV(CD)%		DALI	LUTRON

Specify or consult factory for any other type of LED DRIVER requirements not shown above.

# COVE 2 - (CV2) SERIES CONFIGURATIONS



## (FLX) - FLEXIBLE, FIELD CURVABLE

FLX configuration is flexible, field curvable, field adjustable & field connectable. Runs are shipped in pre-wired and pre-attached 6-module, 69" sections that join end to end. The number of fixtures and modules can vary depending on the overall run length of fixture and or cove requirements. See below for minimum cove width and radius recommended requirements. This system is quoted by the foot and not by sections or modules.

TOP VIEW

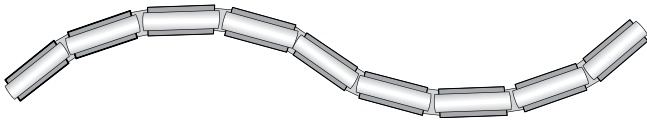

MINIMUM RADIUS AND COVE REQUIREMENTS

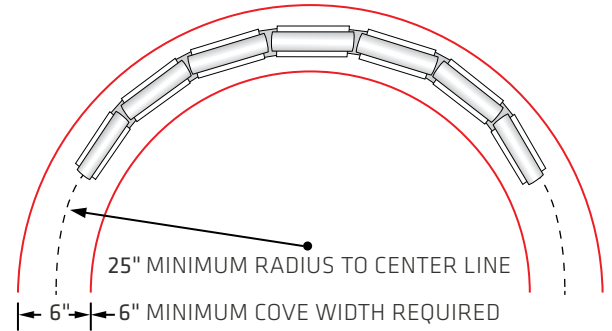

SIDE VIEW

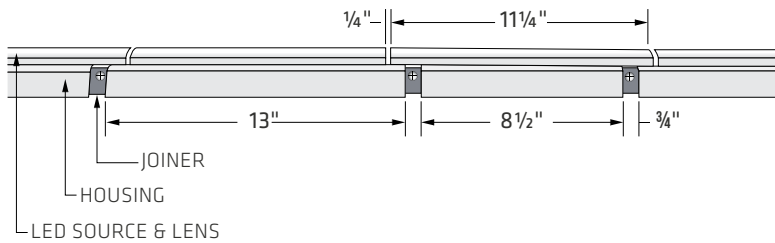

END VIEW

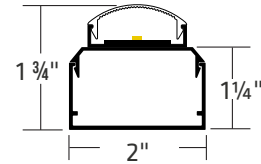

The above dimensions can vary depending on the overall length requirements

## (ST) - STRAIGHT

Straight fixtures can be made up to 12' long. Longer fixtures & runs can be made in the field by connecting multiple fixtures with our joiners. The number and length of the fixtures can vary depending on the total run length or pattern layout requirements. Straight fixtures are also quoted by the foot.

TOP VIEW

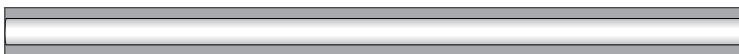

END VIEW

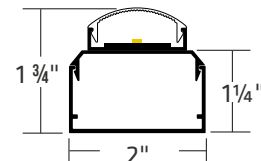

# COVE 2 - (CV2) SERIES

## MOUNTING - FINISH



### MOUNTING OPTIONS

These mounting options apply for both field curvable (FLX) and straight (ST) configurations.

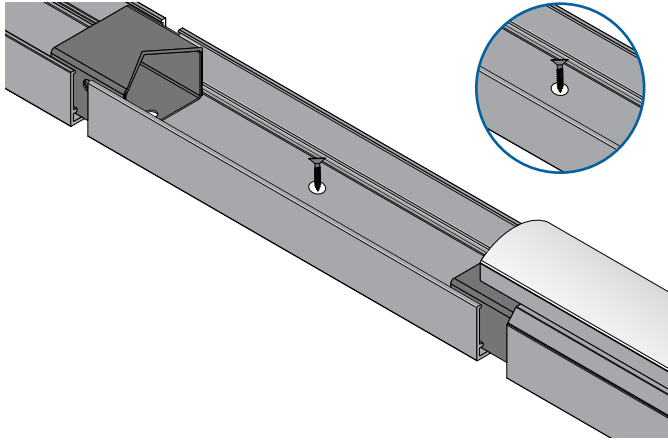

**IM - INSIDE SCREW MOUNT**  
(Standard)

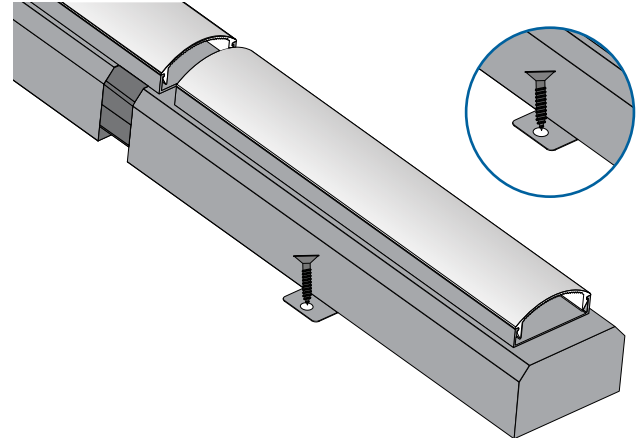

**TM - TAB MOUNT**  
(Optional)

### FINISH OPTIONS

Powder coat and satin anodized.

White, satin and black are standard finishes.

Custom colors and antimicrobial white finish also available.

White or satin finishes are recommended for cove and indirect lighting applications.

The actual color of the product may vary from what is seen on electronic devices.

We cannot guarantee that the color you see on your screen accurately reflects the true color of the product.



**W - WHITE**

(Powder Coat, Standard)



**S - SATIN**

(Clear Anodized, Standard)



**B - BLACK**

(Powder Coat, Standard)

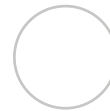

**A - ANTI MICROBIAL**

(Powder Coat White  
Consult Factory)



**C - CUSTOM COLOR**

(Not standard, [provide RAL#](#))

# COVE 2 - (CV2) SERIES

## FIXTURE LENGTHS



### FIXTURE LENGTHS

(FLX)	FIELD CURVABLE	<ul style="list-style-type: none"><li>Specify the overall length of the fixture or cove requirements</li><li>The length and number of fixtures to make the overall length required will be determined by Primus Lighting.</li></ul>
(ST)	STRAIGHT	<ul style="list-style-type: none"><li>Custom patterns and custom runs configurations require a drawing or template.</li></ul>

### (FLX) PATTERNS

To figure out the overall length of a curved pattern, radius and cove measurements are required.

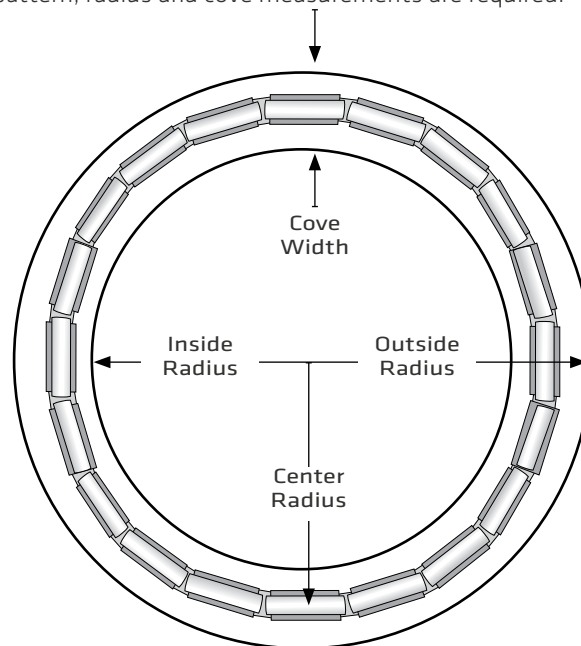

### (ST) PATTERNS

Whipped corners are the optimal solution and offer installation "wobble room" making exact tolerances less critical. For closed coffers we need at least 4 of the following 5 measurements for best results. Mitered corners are possible but require exact measurements.

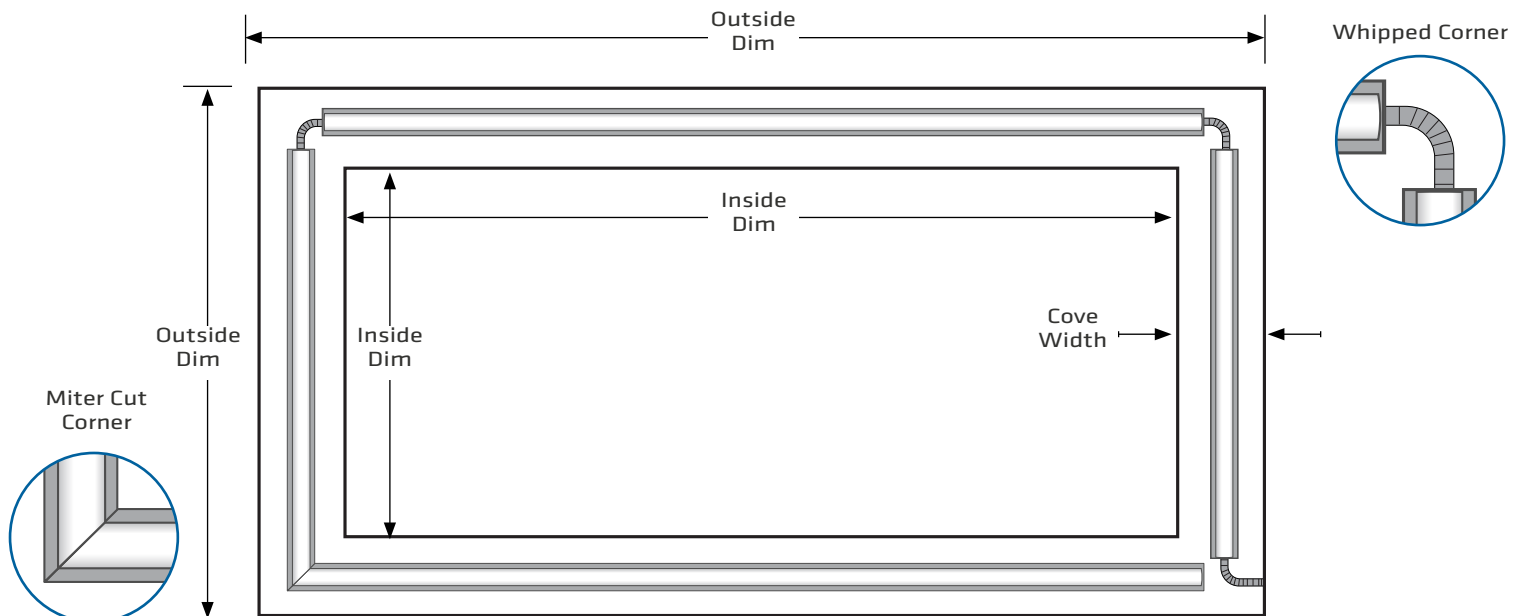

### CEILING COVE LIGHTING

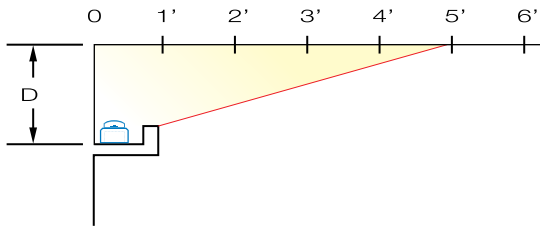

### CEILING COVE FOOTCANDLES

D	1'	2'	3'	4'	5'	6'	7'	8'	9'
12"	110	21	5.7	3	1.6	1.3	1.1	1	1
18"	110	34	13.9	5	3.1	1.6	1.3	1.1	1.1
24"	102	42	17.8	9.5	4	2.7	1.9	1.6	1.1
36"	71	48	27.5	11.6	6.9	6.5	4.5	2.4	1.9

Calculation using "LOW" lumen board 625L x 3500K

### WALL LIGHTING

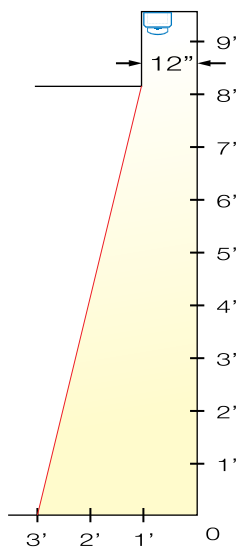

### WALL WASH COVE FOOTCANDLES

	1'	2'	3'	4'	5'	6'	7'	8'	9'
WALL	3.4	3.8	4.7	6.1	8.6	12.6	19.4	43	92
FLOOR	2.4	3.4	3.6	3.4	3.4	2.9	2.6	1.6	1.3

Calculation using "LOW" new lumen board 625L x 3500K

FLOOR

### CONVERSION CHART

LUMENS	27K	3K	35K	4K
LOW	.90	.96	1	1.06
MEDIUM	1.75	1.86	1.97	2.05
HIGH	2.05	2.11	2.57	2.64

### PHOTOMETRICS

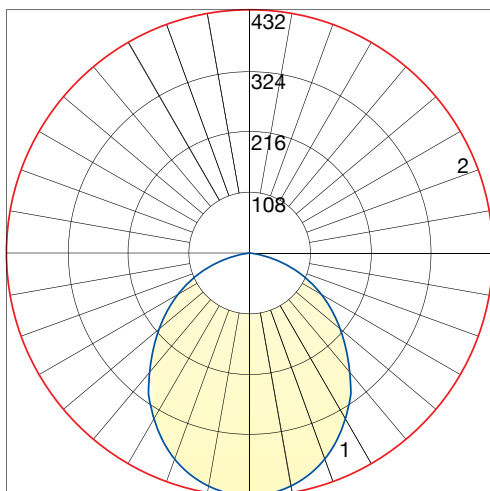

FILE NAME: L10137801R01.IE S

### POLAR GRAPH

Maximum Candela = 432  
 Located at Horizontal Angle = 0 Vertical Angle = 0  
 # 1 Vertical Plane Trough Horizontal Angles (0-180) (Trough Max. Cd.)  
 # 2 Horizontal Cone Trough Vertical Angle (0) (Trough Max. Cd.)